

DIMENSIONS / 尺寸

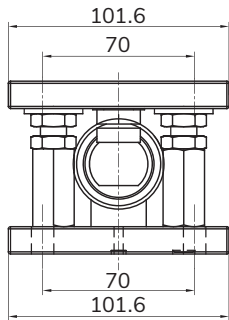

The module doesn't include sensor  
实物模块不包含传感器

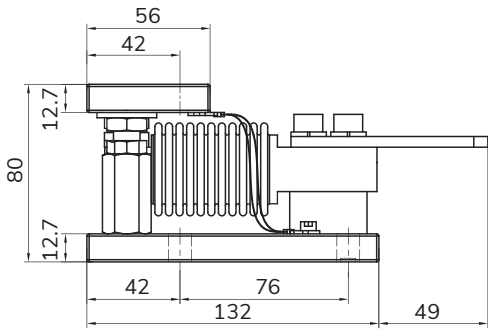
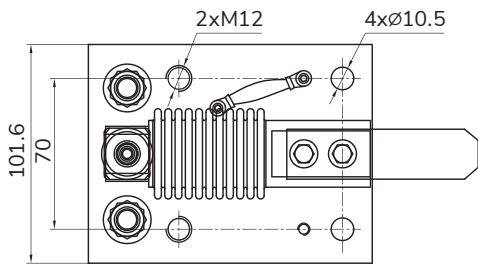

Mounting / 安装示意图

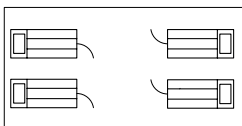

Fixed Module / 固定模块

**Note:** Junction box A02 is required for trimming of a signal  
注: 需配接线盒A02整合信号并输出

CAPACITIES / 量程

CAP (Kg)	SIZE (mm)	Material / 材料	Weight / 不锈钢
5/10/20/30/40/50/75/100/150/200/250/300/500		Stainless steel / 不锈钢	2.4Kg

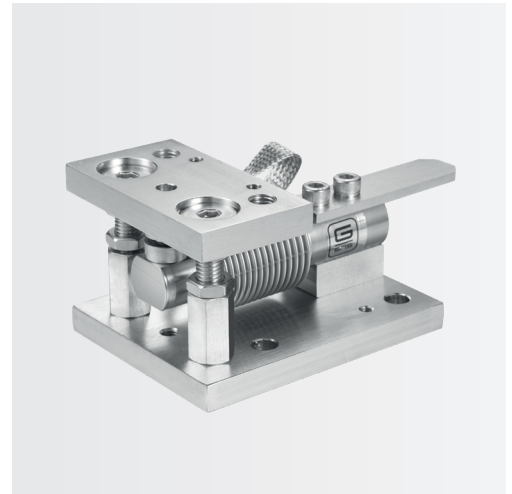

FEATURES & APPLICATIONS / 特点和用途

- Suitable For Bell Type Sensor FC33
- Mainly Used For Small Industrial Weighing Systems

- 适用于传感器FC33
- 主要用于小型工业称重系统

LOAD DIRECTION / 受力方向

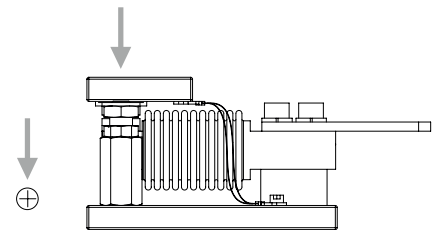

SCHEMATIC WIRING DIAGRAM / 接线图

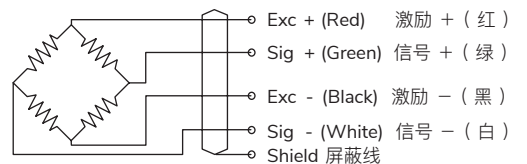

**Note:** Cable shield is not connected to element.  
注: 屏蔽线不与弹性体相连。