

 DIMENSIONS / 尺寸

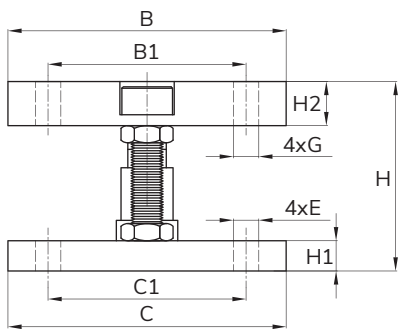

The module doesn't include sensor  
实物模块不包含传感器

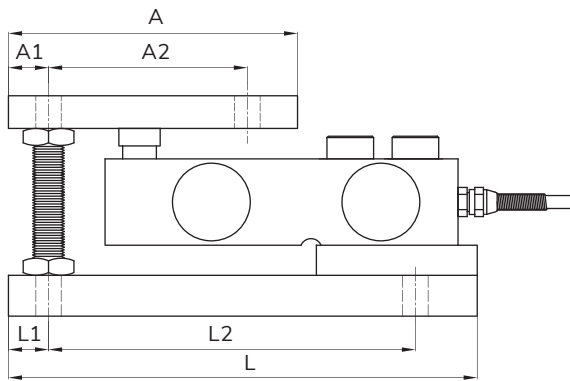
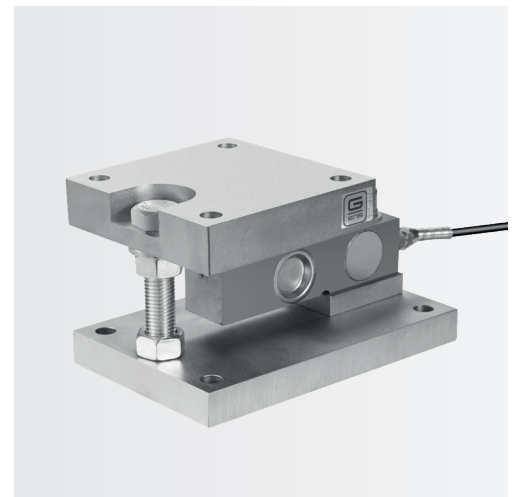

 FEATURES & APPLICATIONS / 特点和用途

- Suitable For Shear Beam Sensor FC31
- Mainly Used For Floor & Platform Scales
- Available In Alloy Steel Or Stainless Steel

- 适用于剪切梁传感器FC31
- 主要用于地秤及平台秤
- 材料可选合金钢或不锈钢

Mounting / 安装示意图

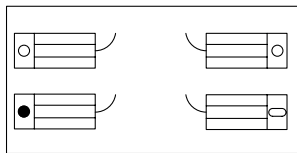

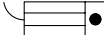
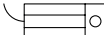
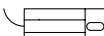
-  Fixed Module / 固定模块
-  Full-floating / 浮动模块
-  Semi-floating / 半浮动模块

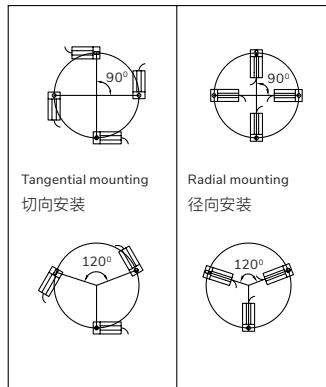

 LOAD DIRECTION / 受力方向

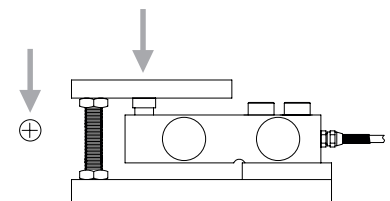

Note: Junction box A02 is required for trimming of a signal

注：需配接线盒A02整合信号并输出

 SCHEMATIC WIRING DIAGRAM / 接线图

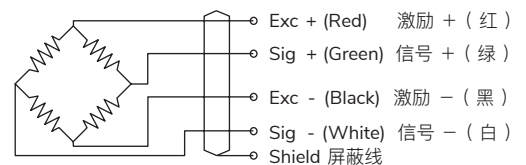

Note: Cable shield is not connected to element.  
注：屏蔽线不与弹性体相连。

 CAPACITIES / 量程

SIZE (mm) CAP (t)	L	L1	L2	A	A1	A2	B	B1	C	C1	H	H1	H2	G	E	Weight / 重量
0.5/1/1.5/2/2.5	177.8	12.7	152.4	114.3	12.7	88.9	114.3	88.9	114.3	88.9	104.9	19	25.4	∅11	∅11	6.5Kg
3/5	235	25.4	184.2	152.4	25.4	101.6	152.4	101.6	152.4	101.6	136.5	24	31	∅17.5	∅17.5	13Kg
7.5/10	355.6	25.4	304.8	203.2	25.4	152.4	203.2	152.4	203.2	152.4	190.5	44.5	44.5	∅20.6	∅20.6	35Kg